

# STARTS GUIDE FOR **Officials**

## STARTS:

### IMPORTANT INFORMATION:

The start command for events up to and including the 400m is “On Your Marks - Set” followed by the gun or other starting apparatus being activated when all athletes are steady in the set position.

The commands “On Your Marks - Set” are also used in the first leg of the 4x100m, 4x 200m and 4x400m Relays.

For races over 400m a Standing Start must be used and the command is “On your Marks” followed by the gun when all athletes are steady.

The Starter should be positioned on the inside of the track so that they have full visual control over all athletes during the start procedure.

**CROUCH START** (up to and including 400m):



“On your Marks”



“Set”

**STANDING START** (for races longer than 400m):



On your marks, walk up to the line. **YOUR FEET MAY NOT MOVE AGAIN!**

### FALSE START:



Second bang or whistle indicates a false start.

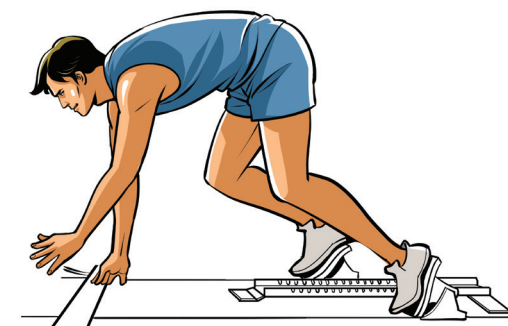

Any athlete making a false start is disqualified. The athlete is shown a Red/Black diagonal card.

# RACE GUIDE FOR Officials

## THE RACE:

The place order of athletes at the finish of the race is decided upon by which athlete's torso crosses the finish line first. The torso is any part of their body not including the head, neck, arms, legs, hands or feet.

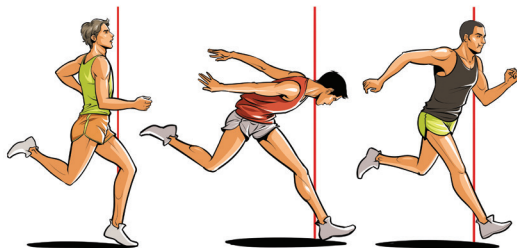

### IMPORTANT INFORMATION: JUDGES

- You must concentrate on the finish.
- Do not speak to each other.
- Don't let yourself be influenced by others
- Be objective and impartial

### HAND TIMING:

- Stopwatch must be reliable.
- It must be able to take split times.
- It must be held the same way for the start and finish.
- All times shall be rounded to the next full 10th of a second. e.g., 9.45 is rounded up and recorded as 9.5 secs. Look at the clock, what time should be recorded on the result sheet?

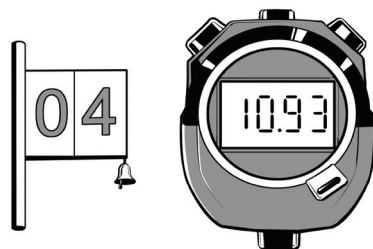

### DISTANCE RACES:

- For races of 800m and over, a lap counting device indicating the number of laps remaining is located by the finishing line.
- Lap scoring sheets should be used to keep the lap times of each athlete and are handed in at the end of the event for events over 1500m.
- A timekeeper should be appointed to call times for the lap scorers.
- Prior to the start of the races time keepers should be allocated the athletes that they will be timing.

The watch is stopped as soon as some part of the athlete's torso reached the plane of the finishing line

The watch is started on the 'smoke or flash' of the gun

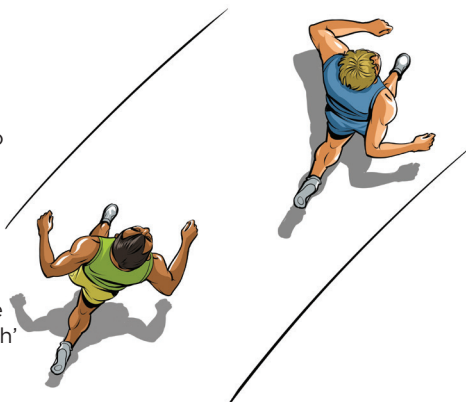

- The lap board is changed when the first athlete enters the home straight.

### DISQUALIFICATION:

Runners or walkers who jostle or obstruct another competitor impeding their progress may be disqualified from the event

All track events up to and including 4x100m relays will be liable for disqualification if they run out of their lane.

In events where athletes run partly in lanes such as 800m, 4x200m and 4x400m relays, athletes must stay in their lane until the break line. From this point on, athletes may leave their lanes and run in lane one. If an athlete cuts in before the 800m break line they shall be disqualified. Disqualification is only done by the Track Referee.

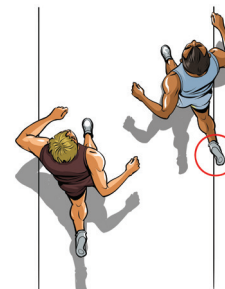
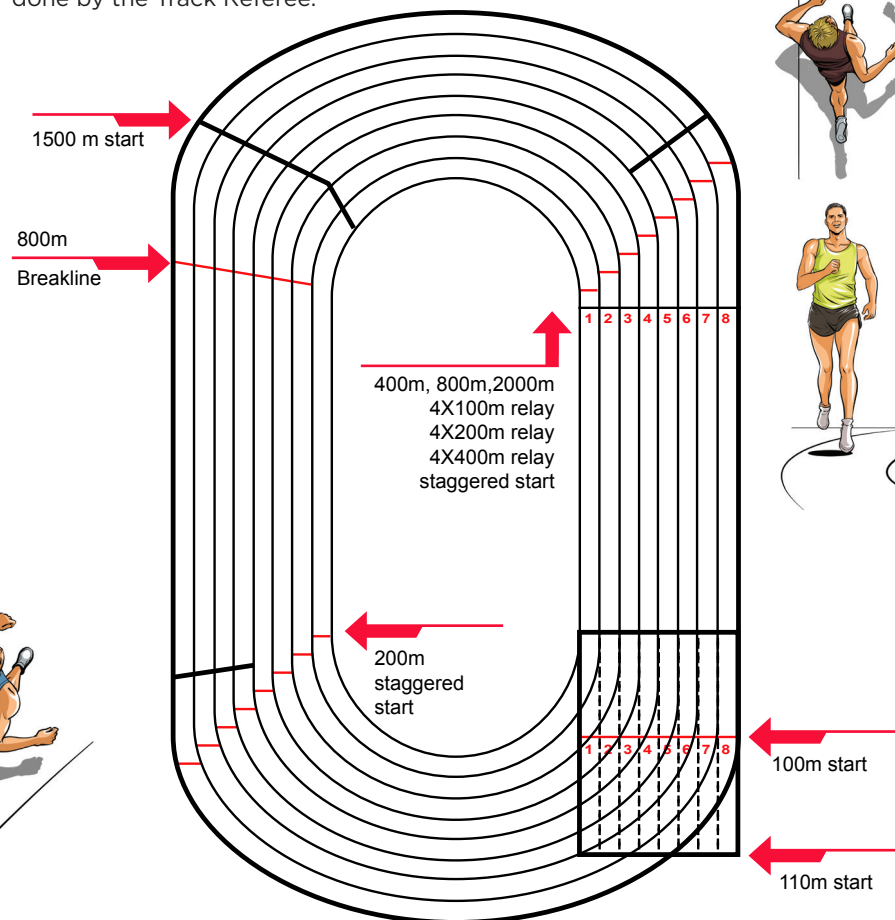

# RELAY GUIDE FOR Officials

## THE RELAY:

### RELAY RACES:

In the takeover zone it's the position of the baton that matters as to whether it's in or out of the take-over zone, it's not the position of the body or limbs of either runner that counts.

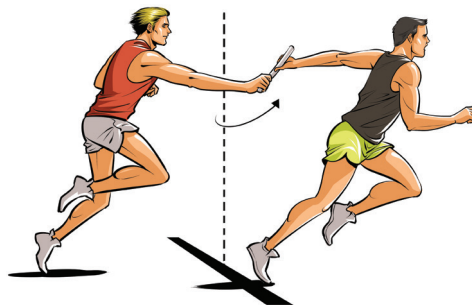

Athlete must be inside change zone when they start to run.

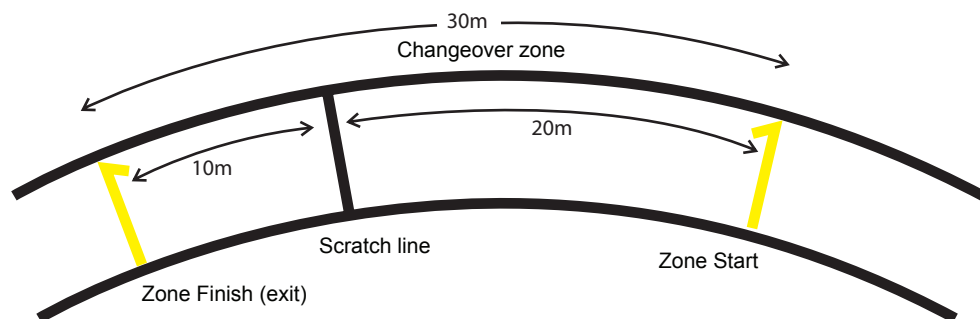

- Baton must be changed inside of Zone (between yellow lines)
- It is the baton that counts

The baton may be changed anywhere in the 30m change zone. The outgoing runner may only start running from the zone



### IMPORTANT RULES:

- Runners must carry the baton by hand.
- Passing of the baton commences when it is first touched by the receiving athlete and is completed the moment it is in the hand of only the receiving athlete..
- If it's dropped, it must be picked up by the runner who dropped and it must be returned to the point where it was dropped before the runner continues in the race.
- It must not be thrown.
- A runner may leave their lane to pick the baton up, but shouldn't interfere with the other runners in doing so.
- After passing the baton a runner must remain in their lane and avoid impeding with the other teams.
- Impeding an opponent after passing the baton may get the team disqualified.

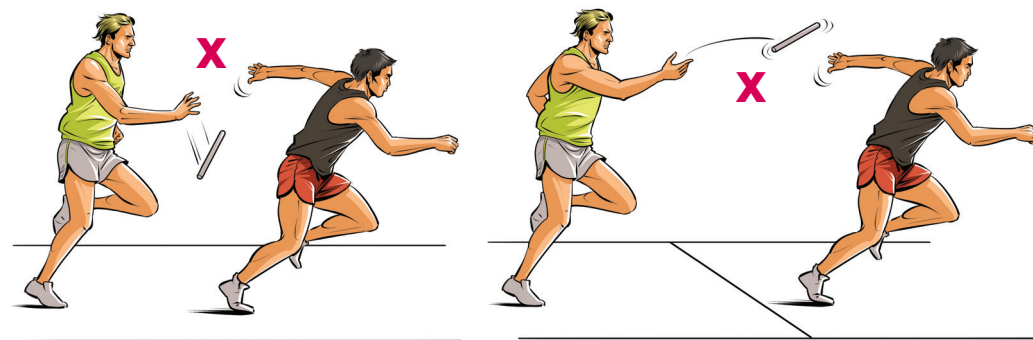

# HURDLES GUIDE FOR Officials

## HURDLES:

An athlete must go over all hurdles in their lane.

Athletes may be disqualified if they:

- ➔ Run around a hurdle.
- ➔ Deliberately knock a hurdle down by pushing or kicking.
- ➔ Trail a leg or foot below the horizontal plane of the top of the hurdle.
- ➔ Impede the progress of athletes in adjacent lanes.
- ➔ Knocks down or displaces hurdle in adjacent lane

**Note:** The accidental knocking down of any or all hurdles does not result in disqualification (the more an athlete knocks down the slower the time).

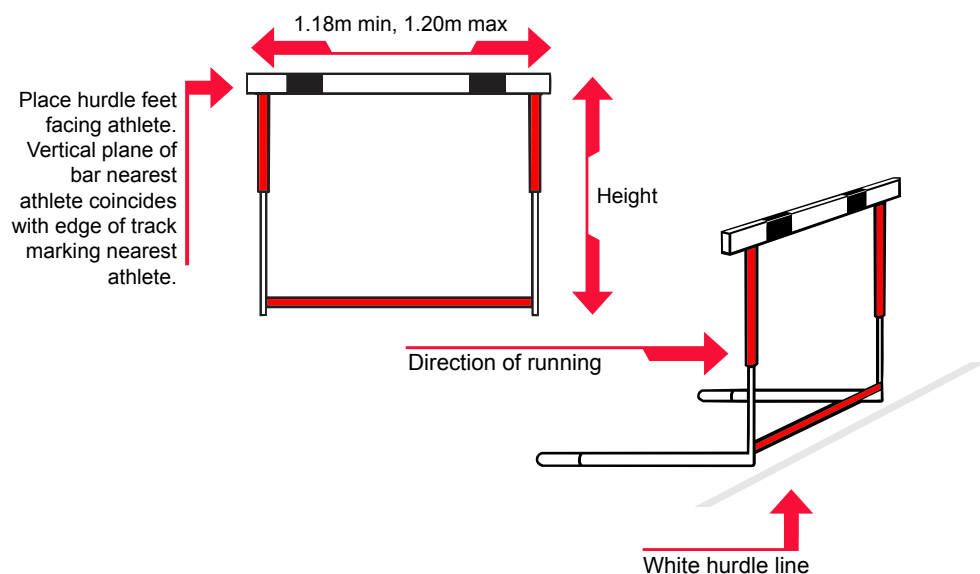

## HURDLE DISTANCES:

Men, Junior Men, Youth Boys and Children Boys			
Distance of Race	From start line to first hurdle	Distance between hurdles	Distance from last hurdle to finish line
80m(Boys - 12&13)	12m	8m	12m
100m(Boys - 14yrs)	13m	8.50m	10.50m
110m (U18, U20, Senior)	13.72m	9.14m	14.02m
300m (U18, U20, Senior)	50m	35m	40m
400m (U20, Senior)	45m	35m	40m

Women, Junior Women, Youth Girls and Children Girls			
Distance of Race	From start line to first hurdle	Distance btwn hurdles	Distance from last hurdle to finish line
80m (Children to Girls 12-14)	12m	8m	12m
100m (U18, U20, Senior)	13m	8.50m	10.50m
300m (U18 / U20)	50m	35m	40m
400m (U20, Senior)	45m	35m	40m

## HURDLE HEIGHTS:

Standard heights of the hurdles:					
	80m H	100m H	110m H	300m H	400m H
Men			1.067m		0.914m
U20			0.991m		0.914m
U18			0.914m	0.838m	0.838m
Boys	0.762m	0.838m			
Women		0.838m			0.762m
U20		0.838m			0.762m
U18		0.762m		0.762m	0.762m
Girls	0.762m				

# HIGH JUMP GUIDE FOR Officials

## HIGH JUMP:

### ORGANISING HIGH JUMP:

- ➔ Check (list) names off and get starting heights
- ➔ Allow practice jumps at a height below the starting level
- ➔ Announce the starting height and subsequent lifts
- ➔ Measure new heights at the start of each round
- ➔ Each competitor gets up to three attempts at each height
- ➔ A jumper is eliminated after three consecutive failures
- ➔ Bar must never be raised by less than 2cm

### FAILURES:

- ➔ Knocking bar off, even if a landing is made before the bar falls
- ➔ Two-foot take off
- ➔ Touching ground or apparatus beyond plane of uprights before jumping
- ➔ Touching uprights while attempting a jump

### SAMPLE SCORE SHEET:

Name	1.20	1.23	1.26	1.29	Best	Place
Bill	O	O	XO	XXX	1.26	3rd
John	XO	XXO	O	XO	1.26	1st
Allan	O	XO	XXO	XXO	1.26	2nd

Winner is athlete with least number of attempts at last height cleared. If this does not split, athlete with least number of failures up to last height athletes cleared. John wins Etc.

O = clearance, X = failure, - = pass

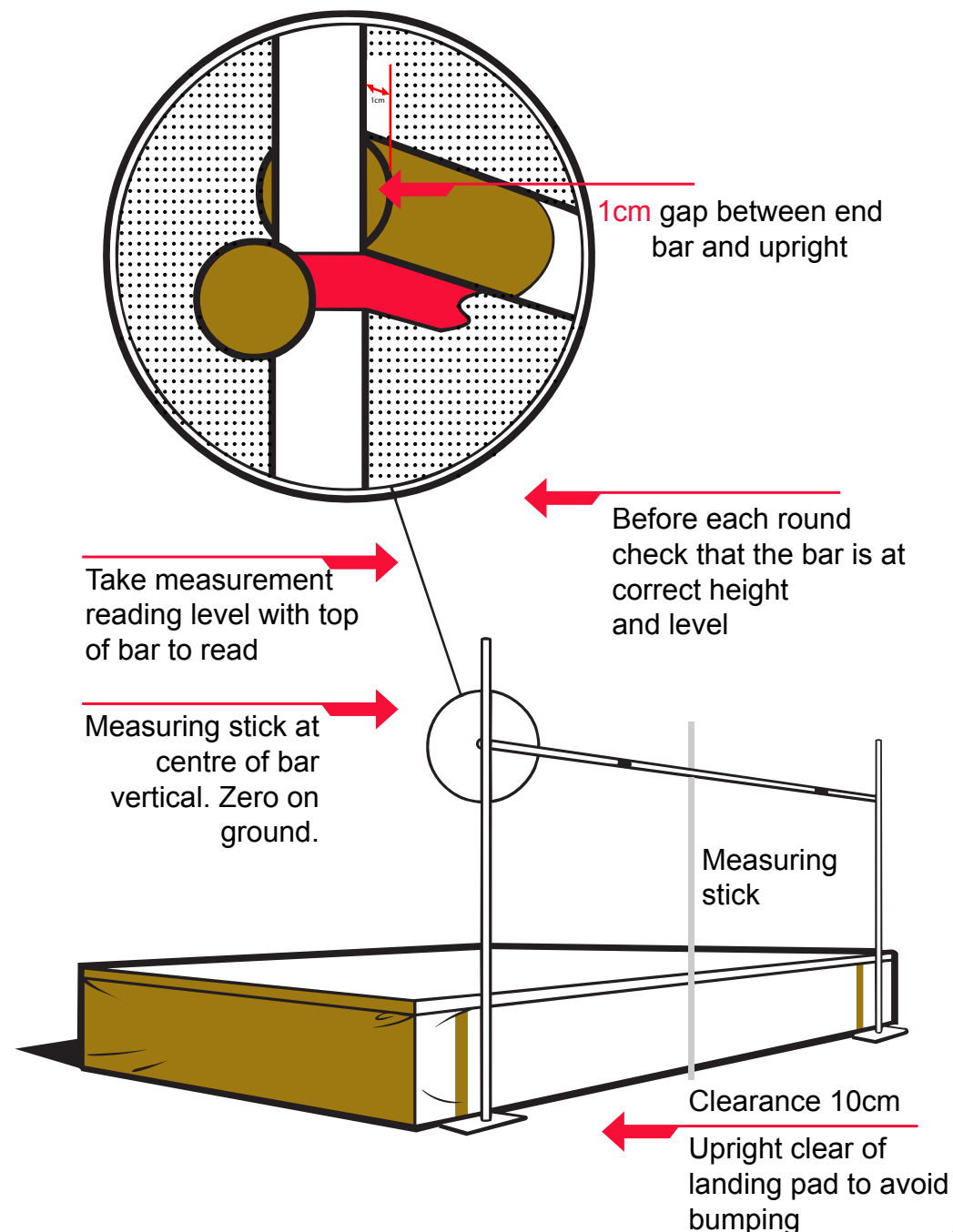

# LONG JUMP GUIDE FOR Officials

## LONG JUMP:

### ORGANISING THE LONG JUMP:

- ➔ Arrange competitors in order
- ➔ Allow a practice jump if there is time
- ➔ Specify number of jumps. (Can be any number 3 to 6)
- ➔ Record all jumps- in a tie, the next best jump counts and so on
- ➔ Pit must be raked level with takeoff board after every attempt

### FAILURES:

- ➔ Foot in front of line at take off
- ➔ Walking back through the pit after the jump, when the first contact with ground outside is closer to the take-off line than the closest break in the sand. (see picture)
- ➔ Somersaults into pit
- ➔ Landing on, or touching ground outside pit and closer to take off line than the mark in the pit.

### SAMPLE SCORE SHEET:

Name				Best	Place
Bill	4.04	4.05	x	4.05	2
John	x	x	-	NM	-
Allan	4.00	4.10	3.99	4.10	1
Bob	3.85	3.92	3.73	3.92	3

X = failure, NM = no measurement, - = pass

**Metre boards** are to be used by athletes up to and including Grade 11. Standard Take off Boards are used from Grade 12 up.

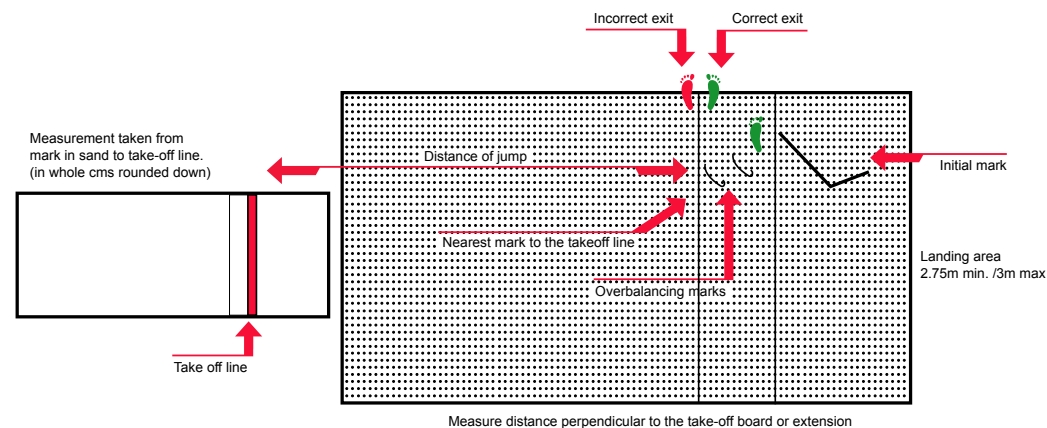
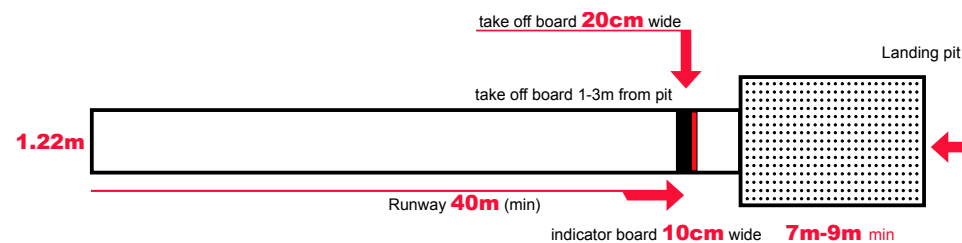
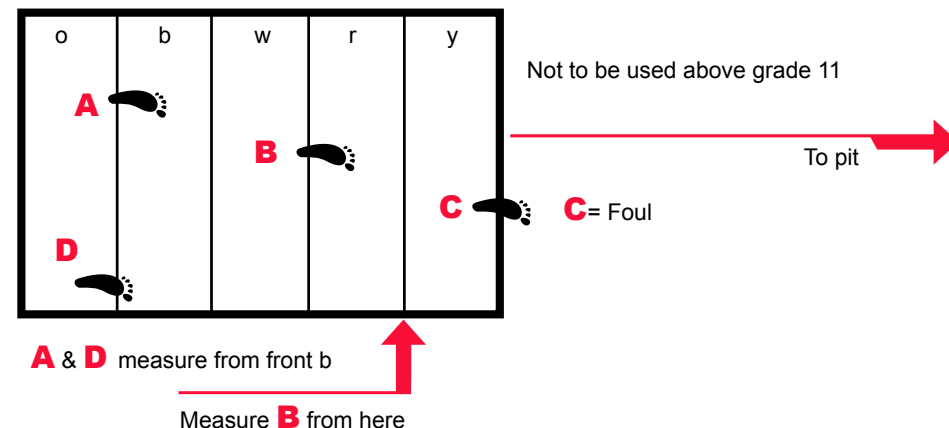

# TRIPLE JUMP GUIDE FOR Officials

## TRIPLE JUMP:

### IMPORTANT INFORMATION:

Young athletes may choose which board they wish to use; eg. 7, 9, 11 or 13 metres. The chosen board may be changed during the event.

Triple jump consists of a hop, step and jump in that sequence

### FAILURES:

- If the athlete does not perform the hop, step, jump sequence.
- If the athlete does not finish the jump phase by landing in the pit.
- If the athlete walks back through the sand towards the take off area after landing.
- If any sort of sommersault is used
- It is not a failure if the sleeping leg touches the ground during jump.

### TRIPLE JUMP SAMPLE SCORE SHEET:

Name				Best	Place
Bill	13.30	12.90	x	13.30	2nd
John	x	x	x	NM	-
Allan	13.45	12.80	13.20	13.45	1st
Bob	12.80	12.80	12.90	12.90	3rd

X = failure, NM = no measurement, - = pass

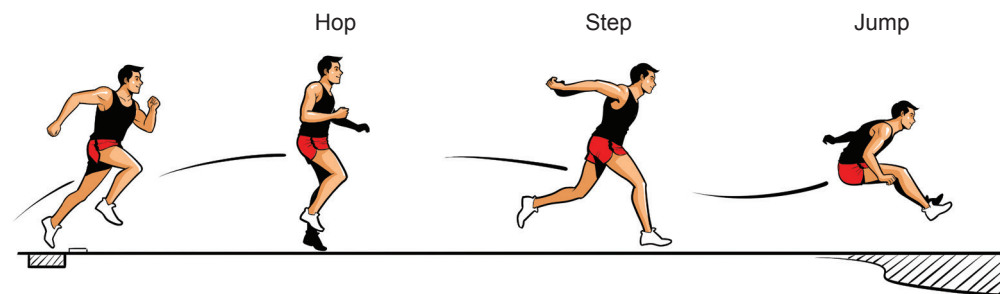
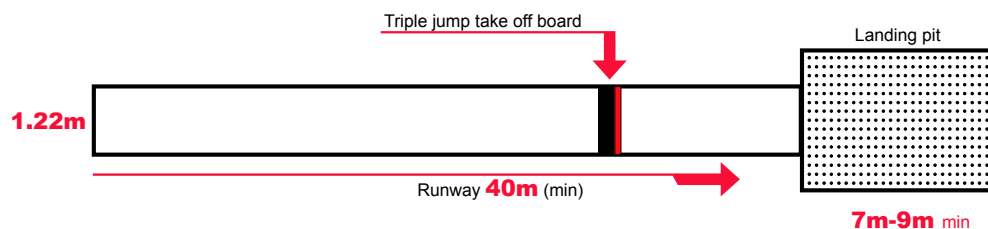

# SHOT PUT GUIDE FOR Officials

## SHOT PUT:

### SHOT PUT WEIGHTS:

	Weight
Grade 7 Girls & Boys	1.00Kg
Grades 8, 9, Girls and Boys	1.50Kg
Grades 10, 11 Girls and Grades 10, Boys	2.00Kg
Grades 12, 13, 14 Girls and Grades 11, 12 Boys	3.00Kg
Girls U16, Women U18	3.00Kg
Grade 13 Boys	4.00Kg
Women U20 and Senior	4.00Kg
Grade 14 Boys	5.00Kg
Boys U16	5.00Kg
Men U18	5.00Kg
Men U20	6.00Kg
Men Senior	7.26Kg

### SAMPLE SCORE SHEET:

Name	Round 1	Round 2	Round 3	Best	Place
Bill	7.17	7.24	X	7.24	1st
John	6.60	6.71	6.50	6.71	3rd
Allan	7.24	7.15	7.12	7.24	2nd

X= Foul / - = Pass

1st and 2nd decided on second best throw

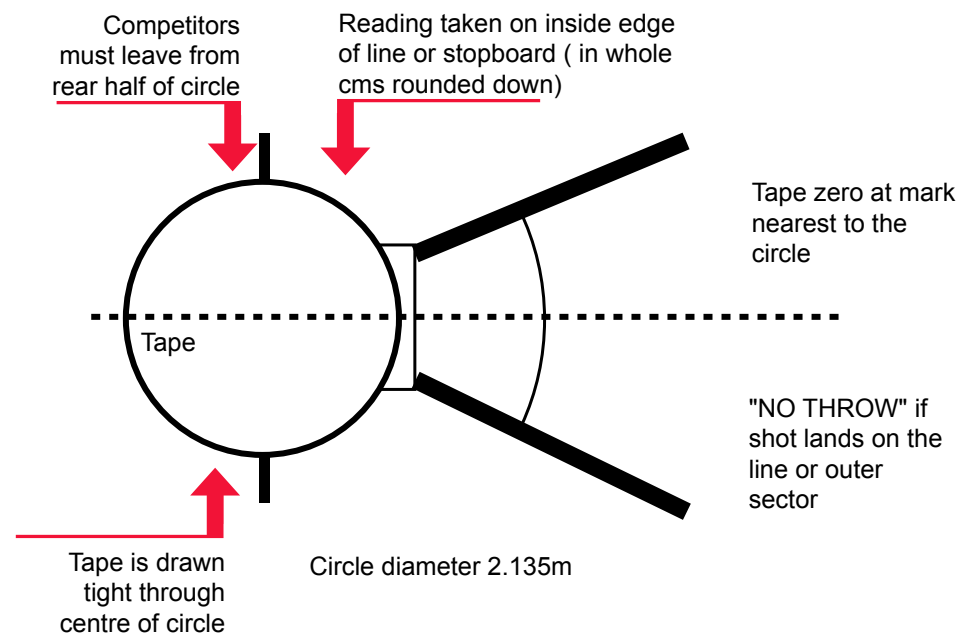

### ORGANISING SHOT PUT:

- Arrange competitors in throwing order
- Allow a practice throw if time permits supervised by officials
- Specify number of throws as may be any number from 3 to 6
- Record all throws. In the event of a tie, next best counts and so on until there is a 'clear' winner

### IMPORTANT RULES:

- The shot must be put from the shoulder with one hand
- The shot must be close to the chin or neck at the start of the put and not drop below this point or be taken back past the shoulder
- The action of putting must start from a stationary position
- The athlete must leave the circle from the rear half of the circle, but only after the shot has landed
- The athlete must not touch the ground outside the circle. The top of the stop board or circle rim.

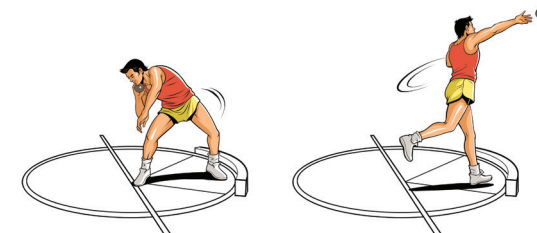



# DISCUS GUIDE FOR Officials

## DISCUS:

### DISCUS WEIGHTS:

	Weight
Grades 7, 8, 9, Girls and Boys	500gms
Grades 10, 11, 12 Girls and Grades 10, 11 Boys	750gms
Grades 13, 14 Girls and Grades 12, 13 Boys	1.00Kg
Girls U16	1.00Kg
Women U18, U20 and Senior	1.00Kg
Grade 14 Boys	1.25Kg
Boys U16, U18	1.50Kg
Men U20	1.75Kg
Men Senior	2.00Kg

### SAMPLE SCORE SHEET

Name	Round 1	Round 2	Round 3	Best	Place
Bill	20.45	19.98	X	20.45	2nd
John	17.28	18.51	16.80	18.51	3rd
Allan	X	20.60	17.89	20.60	1st

X= Foul / - = pass

Supervise this event carefully; the discus is a dangerous implement.

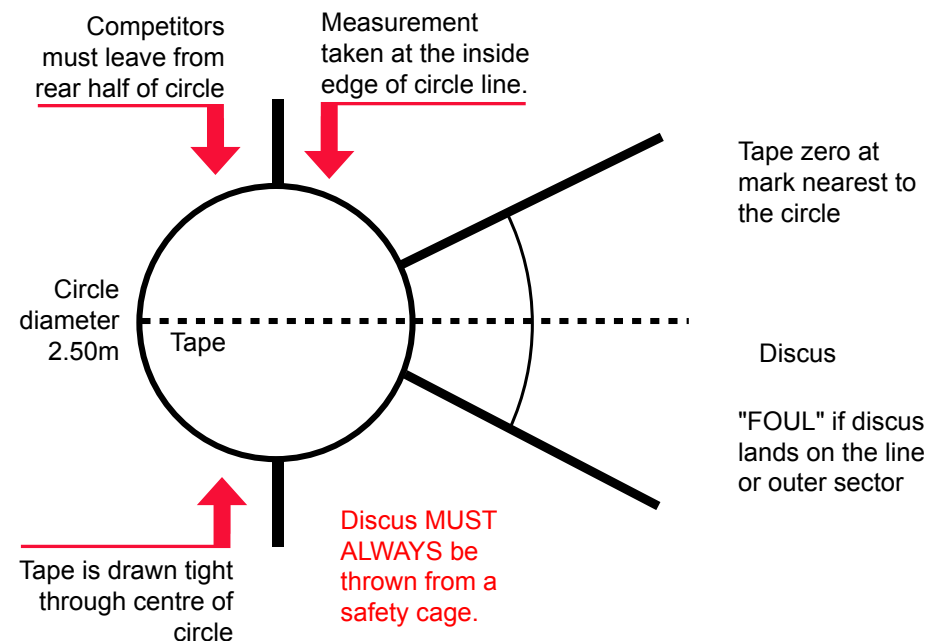

### ORGANISING DISCUS:

- Arrange competitors in throwing order
- Allow a practice throw if time permits
- Specify number of throws as may be any number from 3 to 6
- Record all throws. In the event of a tie, next best counts and so on until there is a 'clear' winner



Common grip

### IMPORTANT RULES:

- The athlete must not touch the top of the circle rim, or the ground outside the circle.
- The thrower must not leave the circle until the discus has landed, and only then through the rear half of the circle.
- Athletes may enter the circle from any direction
- If the discus bounces off the cage and lands in the sector in front of cage, it will be measured unless fouled by the athlete
- All throws must start from a stationery position within the circle.